

Room Thermostat

■ Overview

Model TY6301Z1000 is a two-position (ON or OFF) thermostat for indoor use.

It automatically turns on/off warm air heating equipment, a hot water boiler, or a fan for a plastic greenhouse, glass house, crop storage barn, a livestock stall, or the like for farm or horticultural applications.



■ Features

- Electric two-position control
The liquid filled temperature sensor detects changes in room temperature and activates the microswitch.
- Easy temperature setting
Use the setting knob on the front to set the temperature.

■ Model Numbers

Model No.	Description
TY6301Z1000	Temperature setting range of the room thermostat: -5-60 °C

Safety Precautions

Please read instructions carefully and use the product as specified in this manual. Be sure to keep this manual nearby for quick reference.

Restrictions on Use

This product is targeted for general air conditioning. Do not use the product in a situation where human life may be at risk or for nuclear applications in radiation-controlled areas. If you wish to use the product in a radiation-controlled area, please contact Azbil Corporation.

Particularly when the product is used in applications like the following where safety is especially required, implementation of fail-safe design, redundant design, regular maintenance, etc., should receive appropriate consideration so that the product can be used safely and reliably.

- Safety devices for protecting the human body
- Start/stop control devices for transportation machines
- Aeronautical/aerospace machines

For system design, application design, instructions for use, or product applications, please contact Azbil Corporation. Azbil Corporation bears no responsibility for any result, or lack of result, deriving from the customer's use of the product.

Recommended Design Life (Recommended Peri-od of Use)

It is recommended that this product be used within its design life. The design life is the period during which you can use the product safely and reliably based on the design specifications.

If the product is used beyond this period, its failure ratio may increase due to time-related deterioration of parts, etc. The design life during which the product can operate reliably with the lowest failure ratio and least deterioration over time is estimated scientifically based on acceleration tests, endurance tests, etc., taking into consideration the operating environment, conditions, and frequency of use as basic parameters.

The design life of this product is 11 years.

The design life specified for this product assumes that maintenance, such as replacement of the limited-life parts, is carried out properly. Refer to the section on maintenance in this manual.

Prohibitions for installing this product



Do not install the product in the following environments. Doing so might cause malfunction of the device or device failure in a short period of usage.

- Where special chemicals or corrosive gas (such as ammonia, sulfur, chlorine, ethylenic compound, acids, etc.) exist.
- Where water droplets or excessive damp air exists.
- Where condensation is made on the product.
- Where it would be exposed to direct sunlight, direct wind or rain, or high temperature.
- Where vibrations or shocks are applied. (direct installation on an air conditioner, duct, etc.)
- Where dust or particles can easily enter into the product.
- Where unauthorized persons have easy access.
- Use this product for a controlled fluid that does not damage copper, copper alloy, silver wax, solder, etc.





Cautions for installing this product







- Install this product in a location where representative temperature of the measuring object can be measured.
- Do not install the product in locations such as the following. Temperature may not be correctly measured.
 - Where exposed to warm or cold wind directly.
 - Where air stagnates or there is a draft.
 - Where the product cannot be securely mounted.
- Secure space around the product for maintenance.

Warnings and Cautions







 WARNING	Alerts users that improper handling may cause death or serious injury.
 CAUTION	Alerts users that improper handling may cause minor injury or material loss.

Symbols

	Notifies users that specific actions are prohibited to prevent possible danger. The symbol inside  graphically indicates a prohibited action. (For example, the sign on the left means that disassembly is prohibited.)
	Instructs users to carry out a specific obligatory action to prevent possible danger. The symbol inside  graphically indicates the actual action to be carried out. (For example, the sign on the left indicates general instructions.)

 WARNING	
	Before wiring, setting, maintenance, or replacement, be sure to turn off the power source. Failure to do so may result in electric shock or device failure.
	Ground this product with a ground resistance of less than 100 Ω. Improper grounding may cause electric shock or malfunction.
	If seal connectors or conduits cannot be used, use grommets. Failure to do so might cause electric shock due to touching the terminals.
	After wiring, changing the settings, engineering work, maintenance, or replacement, be sure to reattach the terminal cover. Failure to do so may result in electric shock.
	If you use this product to control a device that could cause a fire such as a heater, be sure to implement safety measures.

<p>IMPORTANT</p> <ul style="list-style-type: none"> • Properly use this product according to the manual for this product and the manuals for other devices connected to this product. • Implement the following safety measures. <ul style="list-style-type: none"> - Create a function to avoid or notify the abnormal conditions to other equipment if this product breaks down. - To use this product for controlling a heating device such as a hot water heater, create a function to prevent dry-heating. If the enclosed liquid leaks, the contacts are welded, etc., the output might get stuck on ON.
--

 CAUTION	
	Install, wire, and use this product under the conditions specified by this manual. Failure to do so may cause fire or device failure.
	Installation and wiring must be performed by personnel qualified to do instrumentation and electrical work. Failure to do so may cause fire or electric shock.
	All wiring must comply with applicable codes and ordinances. Otherwise there is a danger of fire.
	Use crimp terminals with insulation for connections to the product terminals. Failure to do so may cause a short circuit leading to fire or device failure.
	Tighten the terminal screws with the specified torque. Insufficient tightening of the terminal screws may cause fire or overheating.
	Do not disassemble this product. Doing so may cause electric shock or device failure.

■ Specifications

Item		Specifications	
Size	Main unit	114 x 51.5 x 43.5 (mm) * Excluding the protruding part	
	Temperature sensor	Coil shape MAX Ø42 x 40 mm	
Differential gap		2 °C (fixed)	
Switching operation		When the temperature rises, terminal C and L are Closed, terminal C and H are Open. When the temperature falls, terminal C and L are Open, terminal C and H are Closed.	
Switch contact rating	Motor load	125 V AC	250 V AC
	Operating	8.5 A	4.5 A
	Startup	51 A	27 A
Minimum allowable current value		50 mA	
Environmental conditions	Operating conditions	Ambient temperature: -20-70 °C Ambient humidity: 30-90 % RH (without condensation)	
	Transport/storage conditions	Ambient temperature: -20-70 °C Ambient humidity: 30-90 % RH (without condensation)	
Mounting		Mount the thermostat using the mounting holes on the back side of it.	
Wiring		Wire to the terminal screws (M4) on the microswitch. Recommended tightening torque: 0.7-1.0 N·m	
Material	Main unit	Cold rolled steel plate SPCC (plated)	
	Cover	ABS resin	
	Temperature sensor	Copper, copper alloy, silver wax, and solder	
Weight		0.45 kg	
Color	Main unit	Silver	
	Cover	Light gray	
Accessories		Mounting main unit M3 screws (8 mm long, carbon wire for cold heading SWCH) (x3) Hexagonal nuts (soft steel wire rod SWRM) (x3) Washers (brass C2801) (x3) Grommet (nylon resin, black) (x1)	

■ Dimensions

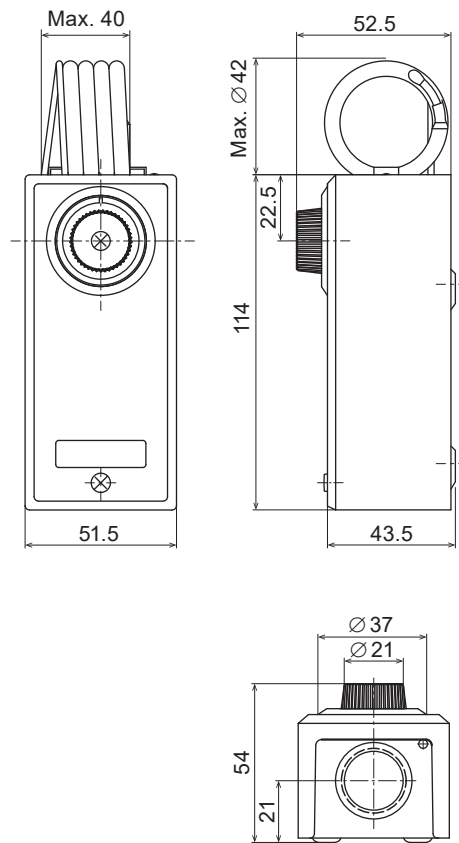



Figure 1 Dimensions (mm)

Installation

CAUTION	
	Install and use this product under the conditions specified by this manual. Failure to do so may cause fire or device failure.
	Installation and wiring must be performed by personnel qualified to do instrumentation and electrical work. Failure to do so may cause fire or electric shock.

Prohibitions for installing this product

Do not install the product in the following environments. Doing so might cause malfunction of the device or device failure in a short period of usage.

- Where special chemicals or corrosive gas (such as ammonia, sulfur, chlorine, ethylenic compound, acids, etc.) exist.
- Where water droplets or excessive damp air exists.
- Where condensation forms on the product.
- Where it would be exposed to direct sunlight, direct wind or rain, or high temperature.
- Where vibrations or shocks are applied. (direct installation on an air conditioner, duct, etc.)
- Where dust or particles can easily enter into the product.
- Where unauthorized persons have easy access.
- Use this product for a controlled fluid that does not damage copper, copper alloy, silver wax, solder, etc.

Cautions for installing this product

- Install this product in a location where the representative temperature of the measuring object can be measured.
- Do not install the product in locations such as the following. Temperature may not be correctly measured.
 - Where exposed to warm or cold wind directly.
 - Where air stagnates or there is a draft.
 - Where the product cannot be mounted securely.
- Secure space around the product for maintenance.

Precautions for installation

This product is not dust-proof. Depending on the location, small creatures such as ants may be able to enter the product. For use in such an environment, take appropriate precautions.

Main unit

- Install this product in a place free of vibration.
- Do not install this product where the product gets splashed by water such as a spa facility or pool.
- Install this product vertically so that the display can be correctly read.
- Do not turn screws other than the cover mounting screw, terminal screws, and ground screw.

Temperature sensor

- Do not seriously damage or scratch the temperature sensor.
- Use this product for a controlled fluid that does not damage the materials of the temperature sensor (copper, copper alloy, silver wax, and solder).
- Do not hold the temperature sensor when carrying the product.
- Use the temperature sensor in an environment where the room temperature takes 18 minutes or more to change by 1°C.

Remark: The relationships between the temperature of the main unit and the temperature of the temperature sensor is not limited.

Installation method

Secure this product using three keyhole-shaped mounting holes inside the main unit.

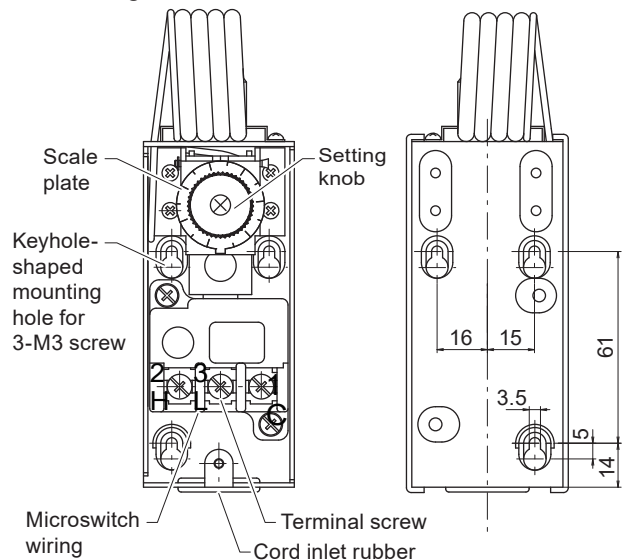
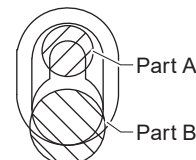

Figure 2 Main unit mounting (mm)

Note: Tighten the screw at part A of the keyhole-shaped mounting hole in the figure below. Tightening the screw at part B deforms the main unit, which causes problems.



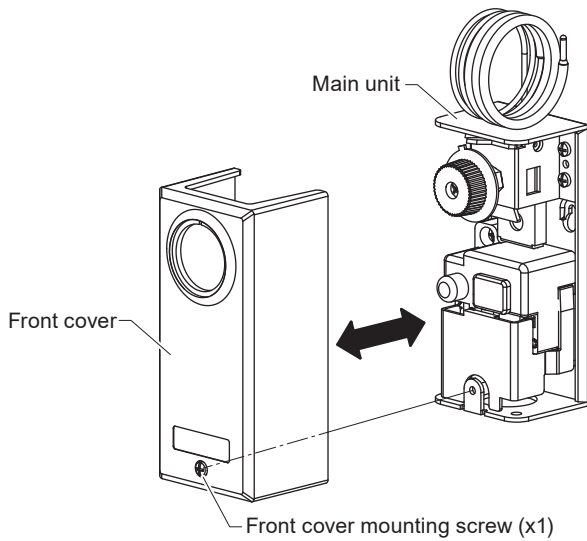

Figure 3 Attaching/detaching the cover

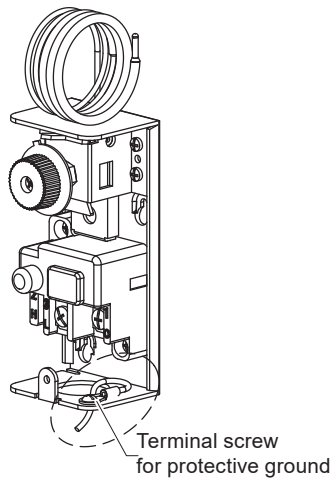

Figure 4 Terminal screw for protective ground

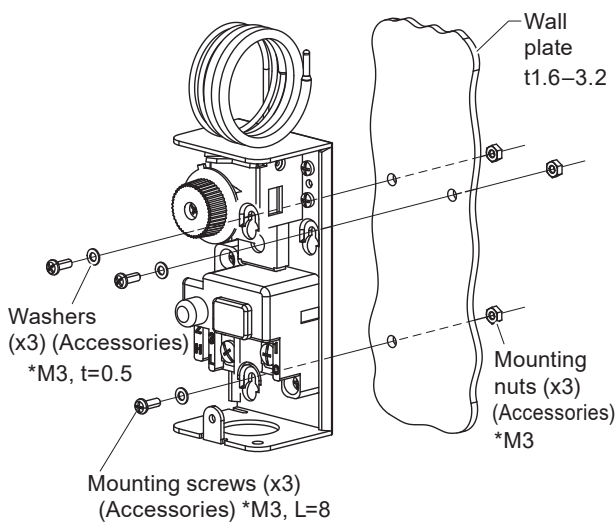

Figure 5 Mounting on the wall

● Attaching the grommet (accessory part)

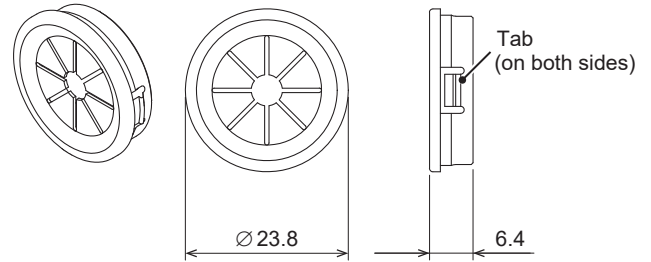

Figure 6 Grommet (mm)

For the included grommet, use the wiring port at the bottom of the main unit shown in Figure 7. If seal connectors or conduits cannot be used, use grommets. Failure to do so might cause electric shock due to touching the terminals. The grommet prevents fingers from entering into the opening in order to prevent electric shock.

* Before wiring, attach the grommet.

- (1) Insert the grommet in the wiring port as illustrated in Figure 7.
- (2) Push the grommet until the tab clicks.
- (3) Ensure that the grommet is firmly inserted.

* Pass wires through the grommet following the instructions in this manual.

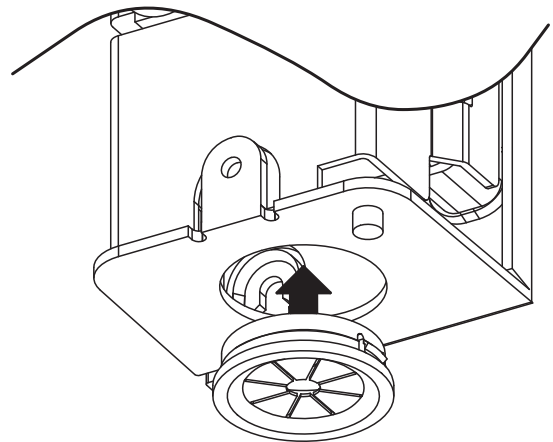













Figure 7 Attaching the grommet

■ Wiring

 WARNING	
	Before wiring, be sure to turn off the power source. Failure to do so may result in electric shock or device failure.
	Ground this product with a ground resistance of less than 100 Ω. Improper grounding may cause electric shock or malfunction.
	If seal connectors or conduits cannot be used, use grommets. Failure to do so might cause electric shock due to touching the terminals.
	After the wiring work, attach the cover at the original position. Failure to do so may result in electric shock.
	If you use this product to control a device that could cause a fire such as a heater, be sure to implement safety measures.

 CAUTION	
	Wire and use this product under the conditions specified by this manual. Failure to do so may cause fire or device failure.
	Wiring must be performed by personnel qualified to do instrumentation and electrical work. Failure to do so may cause fire or electric shock.
	All wiring must comply with applicable codes and ordinances. Otherwise there is a danger of fire.
	Use crimp terminals with insulation for connections to the product terminals. Failure to do so may cause a short circuit leading to fire or device failure.
	Tighten the terminal screws with the specified torque. Insufficient tightening of the terminal screws may cause fire or overheating.

IMPORTANT To use this product properly, follow the instructions described in this manual and the manuals for other devices connected to this product.

- Connect appropriate loads, which satisfy the contact rating specified in the specifications, to the terminals.
- If a timer, auxiliary relays, etc. are used for additional features, select reliable parts and implement them in circuits correctly.
- Correctly supply power, voltage and frequency to the devices as specified in their specifications.
- During wiring, do not scratch, deform, or damage the temperature sensor. Doing so may cause incorrect operation.
- After wiring, check that wires are correctly connected.
Incorrect wiring may cause device damage or malfunction.

● Wiring method

If a cable gland, conduit or grommet is used

- (1) Check the power supply to be used.
 - High insulation performance
 - Enough current capacity
 - (2) Turn off equipment that makes up the circuit.
 - (3) Pass the electric wires through a cable gland or conduit.
 - (4) Pull the electric wires into the case.
 - (5) Connect the wires using the specified round terminals (M4 size).
 - (6) Check that the wires are correctly placed.
 - (7) Reattach the terminal cover and the front cover.
- If cable glands or conduits are not used, use grommets. Hold the wires near the product in order to reduce the tension on the wires.

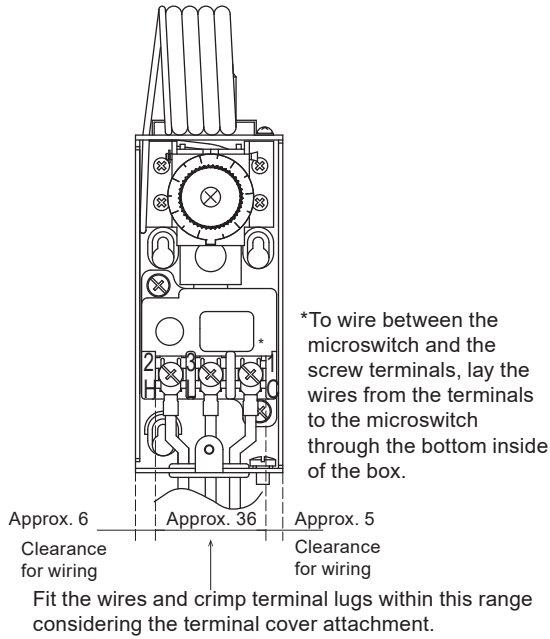

Figure 8 Wiring diagram (mm)

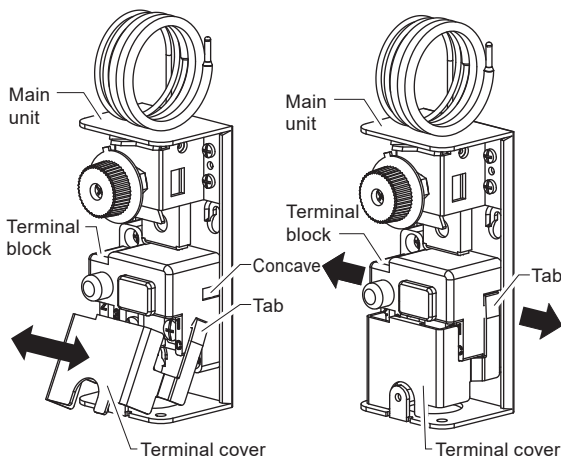
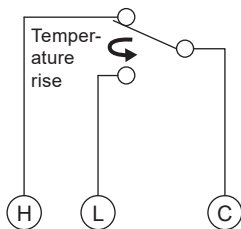

Figure 9 Attaching/detaching the terminal cover

● **Wiring diagram and example**

Terminal screws are provided with the microswitch to connect electric wires. Refer to the wiring diagram below.

- Check terminal markings before making connections.



When the temperature rises, terminal C and L are Closed, terminal C and H are Open.

Figure 10 Internal wiring diagram

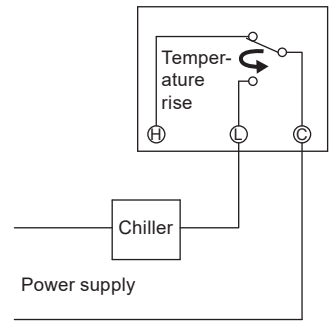

Simple automatic control system that uses the chiller only

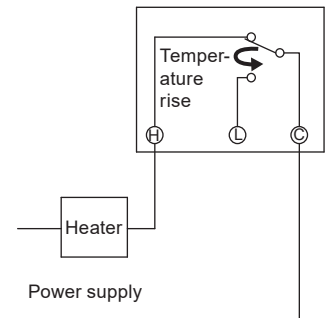

Simple automatic control system that uses the heater only

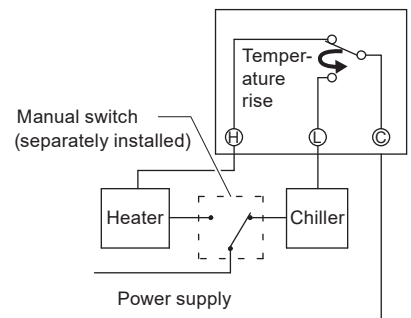

Manual cooling/heating switching method individually equipped with a manual switch

Figure 11 Wiring example

● Instrumentation example

Abnormal temperature alarm for power reception panel and control panel

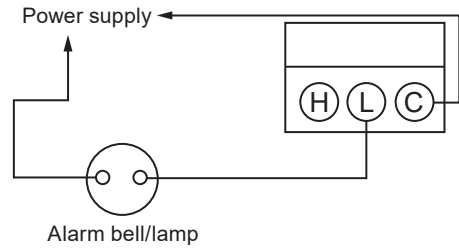
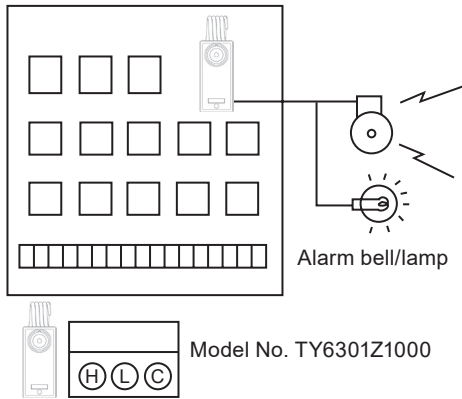

Controlling fan

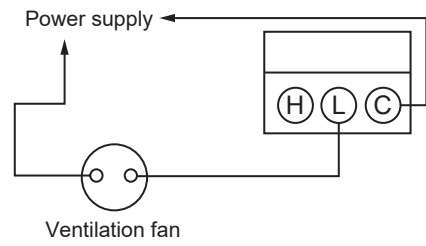
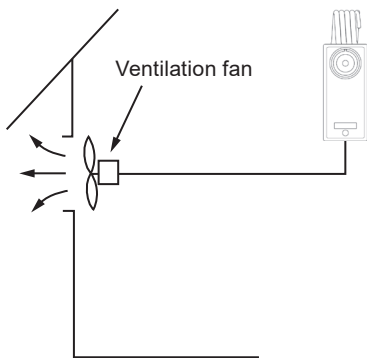

Hot water boiler (controlling circulating pump)

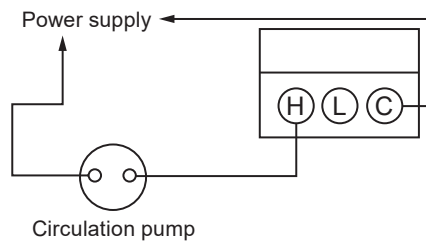
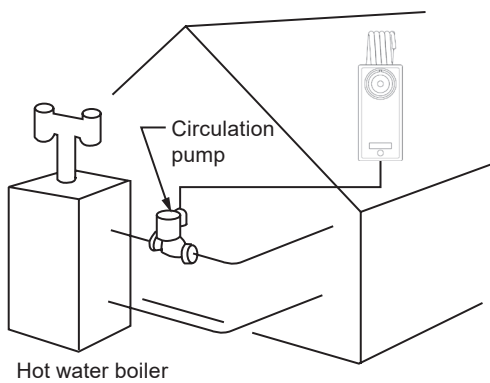

Hot water boiler (controlling solenoid valve)

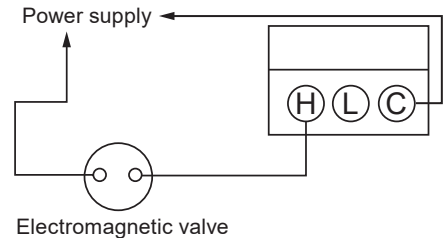
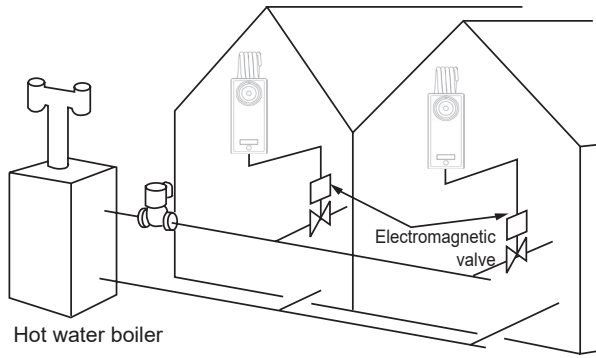

Controlling warm air heater

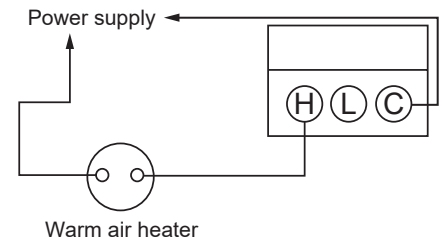
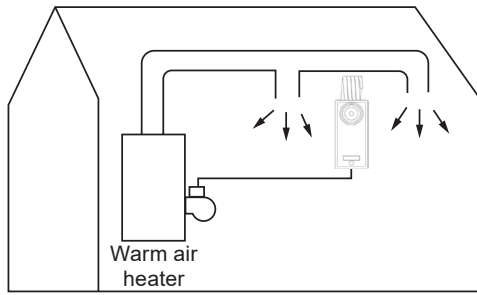

Controlling chiller

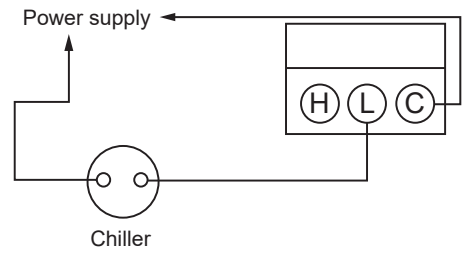
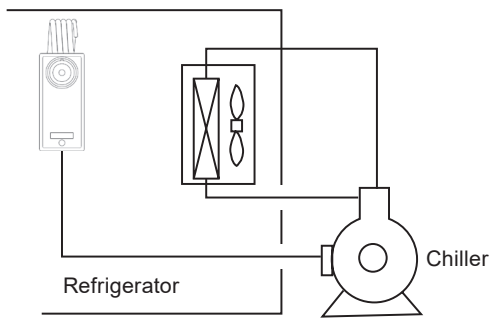

Settings

Note the following points during setup and adjustment.

- Do not turn screws other than the setting knob and terminal screws.

Temperature setting

- Turn the setting knob to set the needle to the desired temperature.
- Reattach the front cover.
- Check the operation.

Operations

When the temperature rises and reaches the setpoint, the contacts between terminal C and H open; after the temperature falls by the amount of the differential gap, the contacts close.

When the temperature rises and reaches the setpoint, the contacts between terminal C and L close; after the temperature falls by the amount of the differential gap, the contacts open.

Be careful when wiring.

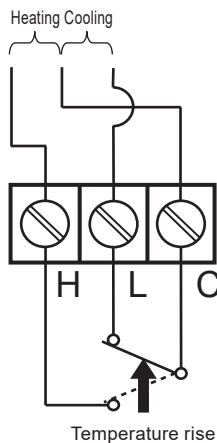

Figure 12 Switch configuration

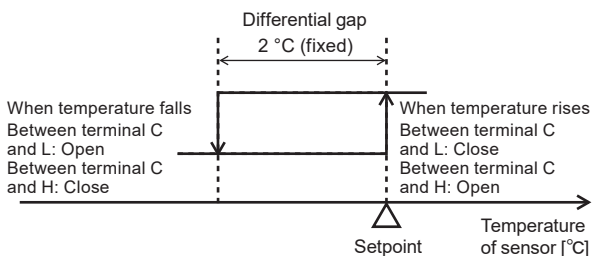

Figure 13 Cooling operation

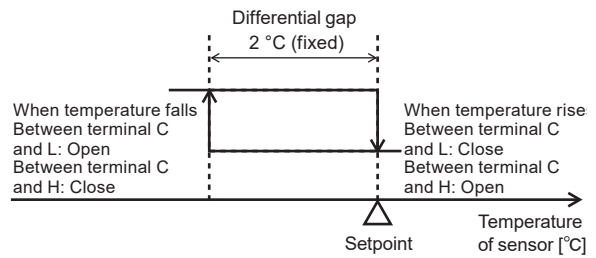

Figure 14 Heating operation





Operation check



IMPORTANT

- Check that the installed device operates normally. If the operation point contains an error, change the set value to remove the error.
- Because of the delayed response of the detecting element, the differential gap may seem to be large. Adjust the mounting location, etc. to eliminate delayed responses.

- Turn on the control target equipment.
- Turn the setting knob to set the setpoint.
- Check that the control target equipment runs or stops normally as intended.
- Turn off the power to the control target equipment until use.

■ Maintenance

 WARNING	
	Before maintenance, be sure to turn off the power source. Failure to do so may result in electric shock or device failure.
	Ground this product with a ground resistance of less than 100 Ω . Improper grounding may cause electric shock or malfunction.
	After maintenance work, be sure to reattach the cover. Failure to do so may result in electric shock.
	If you use this product to control a device that could cause a fire such as a heater, be sure to implement safety measures.

 CAUTION	
	Do not disassemble this product. Doing so may cause electric shock or device failure.

Determine the appropriate cycle of maintenance and inspection, taking into consideration the environmental conditions, frequency of use, etc.

If use is only occasional, inspection before use is recommended.

Maintain and inspect the product following the procedures below.

- (1) Wipe dirt and dust off the temperature sensor using a soft clean cloth or brush so that the element can be effectively exposed to the air.
- (2) Check that the temperature sensor is not deformed, flattened, or damaged.
- (3) In the same way as (1), wipe the setting knob and the terminal posts of the microswitch and the nearby parts.
- (4) Check that the terminal screws are firmly tightened.
- (5) Check that the wires are well insulated.

■ Disposal

Dispose of the product as industrial waste in accordance with your local regulations.

Do not reuse all or part of this product.

This blank page is added for page layout purposes.

This blank page is added for page layout purposes.

azbil

Specifications are subject to change without notice.

Azbil Corporation
Building Systems Company

<https://www.azbil.com/>

Rev. 1.0 Oct. 2022
(J: AI-7661, Rev. 1.0)