

Smart Valve Positioner 100 Series

Model AVP100/102

OVERVIEW

Smart Valve Positioner 100 Series Model AVP100/102 are microprocessor based current-to-pneumatic valve positioners. The 100 Series receives a DC current signal from control devices and controls the openings of valves. In addition to this basic function, the 100 Series has communication capabilities, automatic configuration program, and self-diagnostics functions that increase productivity and efficiency of plant operation.

FEATURES

1. Easy to use

- **Auto setup**

The auto-setup function is a fully-automatic configuration program which specifies the actuator and adjusts the zero and span of the valve. The program can be turned on simply from the internal button so that adjustments to the valve can be performed quickly.

2. Single model for multiple specifications

The 100 Series' settings can be changed without replacing any parts. A single model can be modified to suit any application.

- **Input range:**

Configurable to any required range for split range

- **Flow characteristic:**

Linear, EQ%, Quick opening or custom user characteristics

- **Actuator type:**

Single or double acting actuator (optional reversing relay required)

3. Valve diagnostic (Model AVP102 only)

Following parameters can be monitored by HART communicator or Control Valve Maintenance Support System "Valstaff".

- Stick Slip
- Total Stroke
- Travel Histogram
- Cycle Count
- Shut-Off Count
- Max. Travel Speed.

4. Positive seating

The positive seating function completely shuts off the valve if the input signal becomes lower than previously set. This in turn enhances the full shut-off capabilities of the valves.



5. Easy maintenance

The electrical circuit section and air circuit section are completely separate, making the maintenance of the air circuit section at the work site easy. An Auto/Manual switch is standard equipment, so it is also easy to check the operation of the valve. (However, it is not available for the double-acting actuator.)

FUNCTIONAL SPECIFICATIONS

Applicable actuator

- Single acting actuator
- Linear and rotary motion actuator

Approvals

CCC Intrinsically safe approval for model AVP100

Ex ia IIC T4 Ga

The barriers should be CCC certified types and comply with the following condition as follows.

$V_i=30\text{ V}$, $I_i=100\text{ mA}$, $P_i=1\text{ W}$, $C_i=5\text{ nF}$, $L_i=0.22\text{ mH}$

CCC Intrinsically safe approval for model AVP102

Ex ia IIC T4 Ga

The barriers should be CCC certified types and comply with the following condition as follows.

$U_i=30\text{ V}$, $I_i=100\text{ mA}$, $P_i=690\text{ mW}$, $C_i=26\text{ nF}$, $L_i=0.22\text{ mH}$

The circuit shall be considered to be connected to ground from a safety point of view.

Control signal input

4-20 mA DC (Split Range Configurable-4 mA span Min.)

Input resistance

Model AVP100: 300 Ω typically / 20 mA DC (Intrinsically safe: 350 Ω typically / 20 mA DC)

Model AVP102: 400 Ω typically / 20 mA DC

Output characteristics

- Linear, Equal percentage, Quick opening
- Custom user characteristics (16 points)

Stem travel range

Feedback lever Angle $\pm 4^\circ$ to $\pm 20^\circ$

Valve stem rotation 90° max. (rotary motion actuator)

Bypass operation

Auto / Manual switch (For single acting actuator only)

Air supply pressure

140 to 700 kPa (1.4 to 7.0 kgf/cm²)

Air consumption

4 L(N)/minutes maximum at 140 kPa (1.4 kgf/cm²)

5 L(N)/minutes maximum at 280 kPa (2.8 kgf/cm²)

6 L(N)/minutes maximum at 500 kPa (5.0 kgf/cm²)

Maximum air deliver flowrate

110L(N)/minutes at 140 kPa (1.4 kgf/cm²)

Lightning protection

Peak value of voltage surge: 12 kV

Peak value of current surge: 1000A

Vibration tolerance

2G (5 to 400 Hz) with standard mounting kit on Azbil Corporation's HA actuator

Ambient temperature limits

-40 °C to +80 °C for general model

CCC Intrinsically safe: -40 °C to +60 °C

HART communication limit -20 °C to +80 °C

Ambient humidity limits

10 % to 90 % RH

Configuration tools

Model CFS100 (Field Communication Software)

PERFORMANCE SPECIFICATIONS

Accuracy

For 8 mA \leq input signal span \leq 16 mA

$\pm 1\%$ F.S. ($\pm 2.5\%$ with custom output characteristics)

For 4 mA \leq input signal span < 8 mA, $\pm 1.5\%$ F.S.

PHYSICAL SPECIFICATIONS

Finish

Baked acrylic

Color

Dark blue

Material

Body: Aluminum casting

Pilot relay cover: PBT

Weight

Positioner: 1.7 kg

INSTALLATION

Air connections

1/4NPT internal thread

Electrical connections

1/2NPT internal thread

Specifications for instrument air (JIS C1805-1 (2006))

Particles

Maximum diameter 3 μm

Oil mist

Less than 1 ppm at mass

Humidity of the air supply

The dew point should be at least 10 °C lower than the temperature of this device.

To meet the above specifications for instrument air, install the air purification devices listed in Table 1 properly in the specified installation location.

Table 1. Examples of air purification devices

Installation location	Air purification device	SMC Corp.	CKD Corp.
Compressor outlet or main line	Line filter	AFF Series	AF Series
	Mist separator	AM Series	
Terminal device	Air combination	AM150 or AM250 series	M3000 (S type)

TYPICAL INSTALLATION

Figure 1 shows wiring for model AVP100/102.

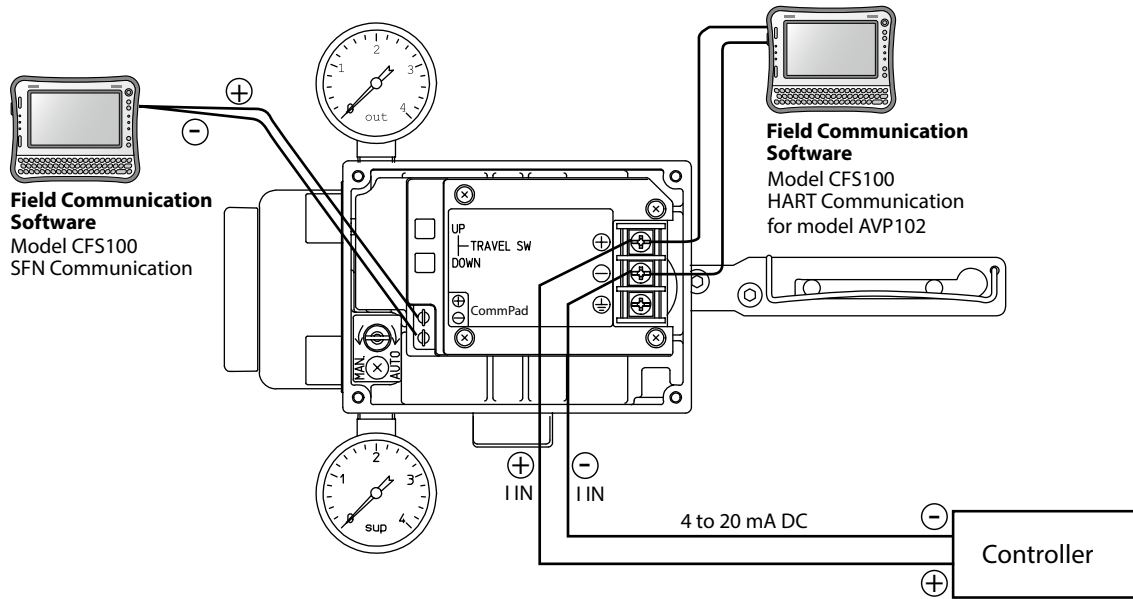

Figure 1. Wiring for model AVP100/102

MODEL SELECTION

Model	Selections	Options
AVP100	(1)	(2) (3) (4) (5)
Analog Signal (4 to 20 mA.DC.)		
AVP102	(1)	(2) (3) (4) (5)
Analog Signal (4 to 20 mA.DC.) with HART communication protocol		

		Code
(1) Structure	Water-proof	P
	CCC Intrinsically safe	H
(2) (3) Supply Air-pressure Classification Pressure gauge T-joint	None	XX
	140 < Ps ≤ 150 kPa with T-joint and pressure gauge (200 kPa)	1X
	150 < Ps ≤ 300 kPa with T-joint and pressure gauge (400 kPa)	2X
	300 < Ps ≤ 450 kPa with T-joint and pressure gauge (600 kPa)	3X
	450 < Ps ≤ 700 kPa with T-joint and pressure gauge (1000 kPa)	5X
(4) (5) Option	None	XX
	HART Communication -20 to +80 °C (This code must be selected for Model AVP102)	HA
	With bracket for PSA1, 2	YS
	With bracket for PSA3, 4	YQ
	With bracket for HA2, 3	YT
	With bracket for HA4	YN

Configuration Following shows default and optional settings of each configurable parameter of the 100 series
 Useless otherwise specified, the 100 series will be shipped with the following configuration

1. Input control signal	4 to 20 mA	The minimal span for custom range = 4 mA
2. Output characteristic	Linear	EQ or QO can be ordered or set by user.
3. Valve action	Direct (Plug above seat)	Reverse (Plug below seat) can be ordered or set by user.

DIMENSIONS

[Unit:mm]

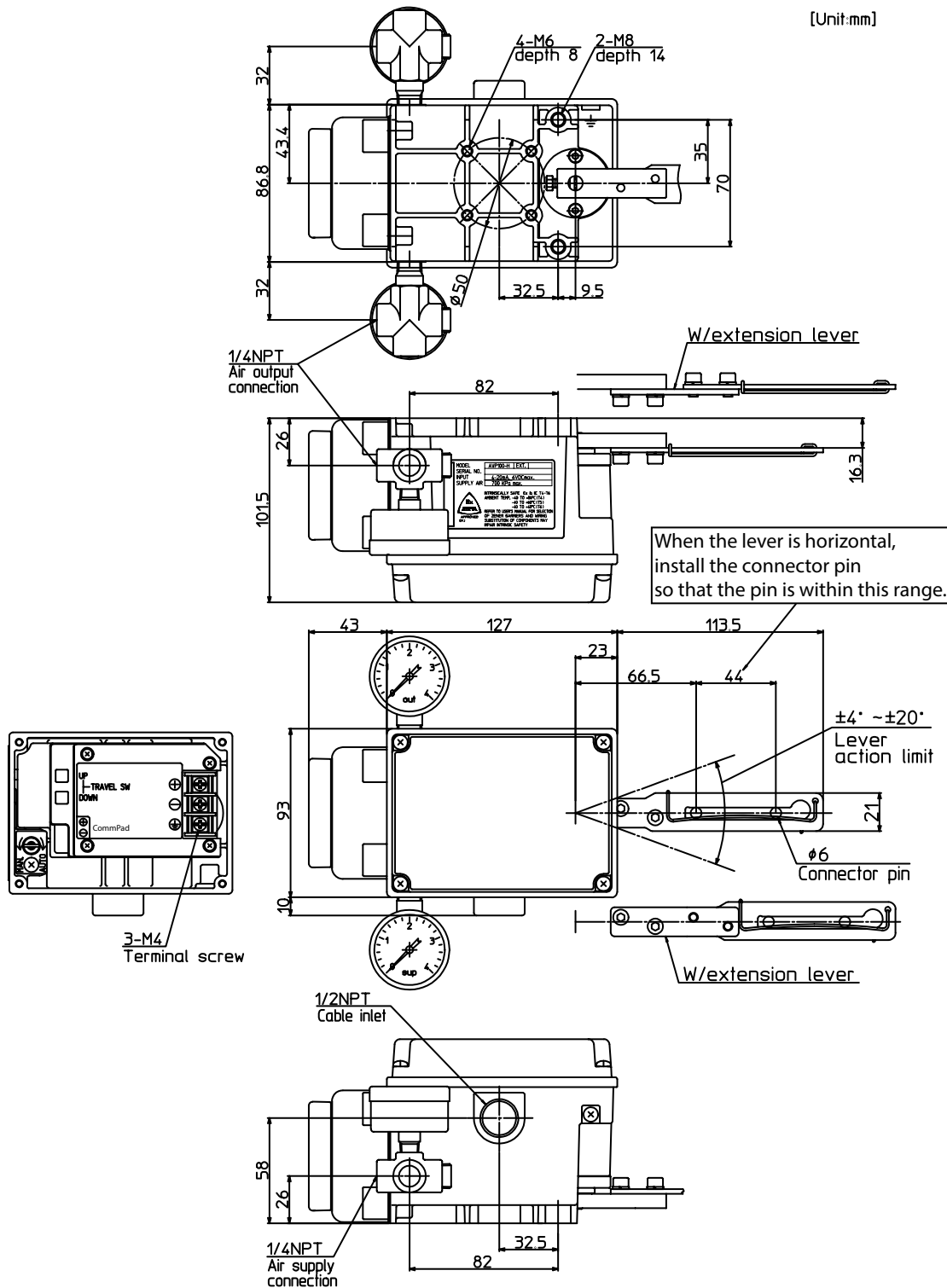

Please read "Terms and Conditions" from the following URL before ordering and use.
<https://www.azbil.com/products/factory/order.html>

Specifications are subject to change without notice.



Azbil Corporation
 Advanced Automation Company

1-12-2 Kawana, Fujisawa
 Kanagawa 251-8522 Japan
 URL: <https://www.azbil.com/>

1st edition: Sep. 2001
 11th edition: May 2024

No part of this publication may be reproduced or duplicated without the prior written permission of Azbil Corporation.